

**SCREW ON HERMETIC JACK RECEPTACLE
SPECIAL REMOVABLE PIN**

R125.609.080

Series : SMA

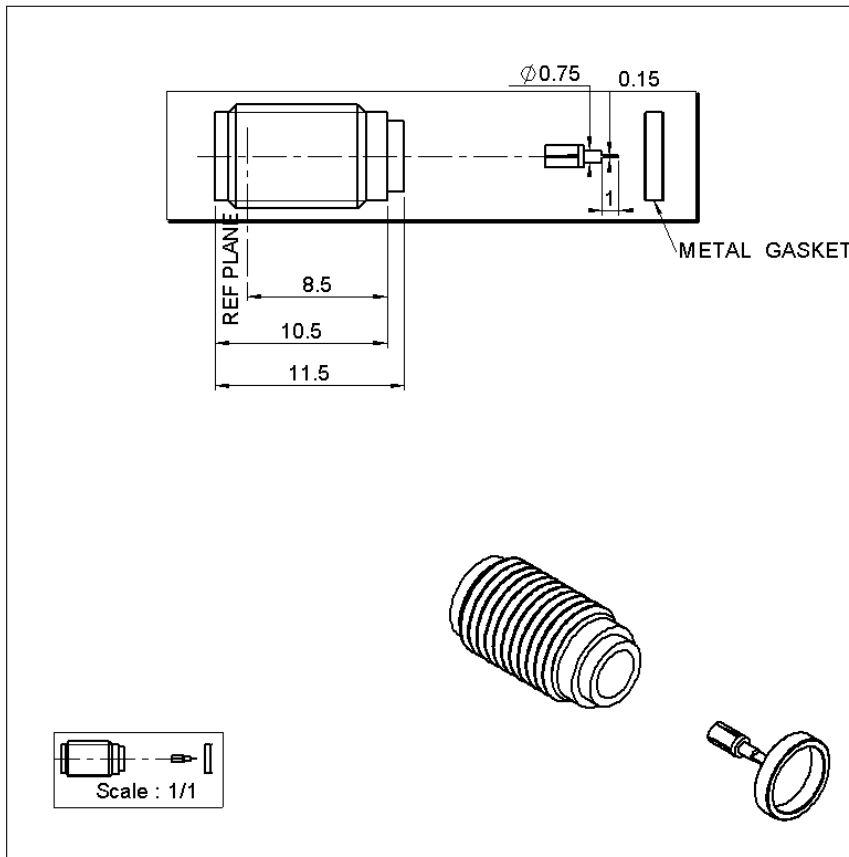

All dimensions are in mm.

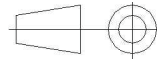

COMPONENTS	MATERIALS	PLATINGS (µm)
BODY	STAINLESS STEEL	GOLD 0.5 OVER NICKEL 2
CENTER CONTACT	BERYLLIUM COPPER	GOLD 1.3 OVER NICKEL 2
OUTER CONTACT	-	-
INSULATOR	PTFE	-
GASKET	ALUMINIUM ALLOY	-
OTHERS PARTS	BERYLLIUM COPPER	GOLD 1.3 OVER NICKEL 2
-	-	-
-	-	-

Issue : 0431 C

In the effort to improve our products, we reserve the right to make changes judged to be necessary.



SCREW ON HERMETIC JACK RECEPTACLE

R125.609.080

SPECIAL REMOVABLE PIN

Series : SMA

PACKAGING

SPECIFICATION

Standard	Unit	Other
1	-	Contact us

ELECTRICAL CHARACTERISTICS

Impedance		50 Ω
Frequency		0-18 GHz
VSWR	1.10 * +	0.010 x F(GHz) Maxi
Insertion loss		0.3* √F(GHz) dB Maxi
RF leakage	- (NA - F(GHz)) dB mini
Voltage rating		500 Veff Maxi
Dielectric withstanding voltage		1000 Veff mini
Insulation resistance		5000 MΩ mini

ENVIRONMENTAL

Operating temperature	-65/+105 ° C
Hermetic seal	10-5 Atm.cm ³ /s
Panel leakage	NA

OTHERS CHARACTERISTICS

Assembly instruction

Others :

* Coaxial Transmission Line Only

MECHANICAL CHARACTERISTICS

Center contact retention		
Axial force – Mating end		27 N mini
Axial force – Opposite end		27 N mini
Torque		2.8 N.cm mini
Recommended torque		
Mating		NA N.cm
Panel nut		280 N.cm
Mating life		500 Cycles mini
Weight		1.446 g

Issue : 0431 C

In the effort to improve our products, we reserve the right to make changes judged to be necessary.



SCREW ON HERMETIC JACK RECEPTACLE

R125.609.080

SPECIAL REMOVABLE PIN

Series : SMA

PANEL DRILLING

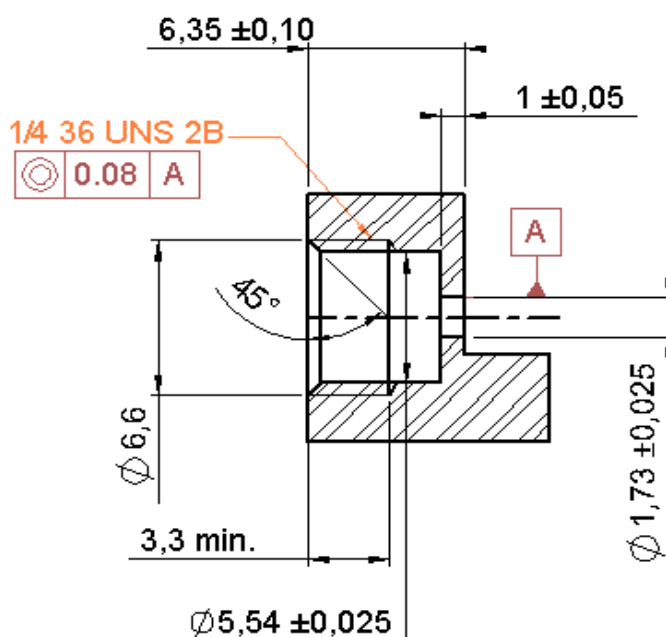

RECOMMENDED MOUNTING HOLE DETAIL

Panel deformation less than 25µ

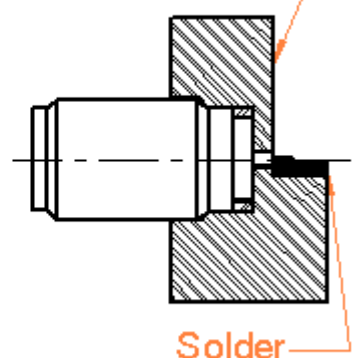

Assemble metal gasket onto connector.
 Screw both parts into the housing.
 Tighten the connector up to 280Ncm +or-
 10Ncm (use special tooling set RADIALL
 R282 341).
 Thus the connexion hermeticity is
 guaranteed at $1 \cdot 10^{-5}$ atm. cm³/s.
 Then solder the pin on the track.
 Be careful not to put too much solder.

Issue : 0431 C

In the effort to improve our products, we reserve the right to make changes judged to be necessary.

